



**ROEMHELD**  
HILMA ■ STARK

# Components for Wind Power Plants

## Rotor locks and more





REpower Systems SE, Photo: Jan Oelker

## Safe system maintenance by the hydraulic and electromechanical rotor lock

Maintenance of wind power plants especially in off-shore installations make the highest demands on man and material. Harsh weather conditions at sea make the work difficult.

To provide the maximum possible protection for employees and the required safety at work, ROEMHELD has developed – for the operators and manufacturers of wind power plants – a hydraulic and electromechanical rotor lock that safely, reliably and quickly locks the rotor blade during maintenance works.

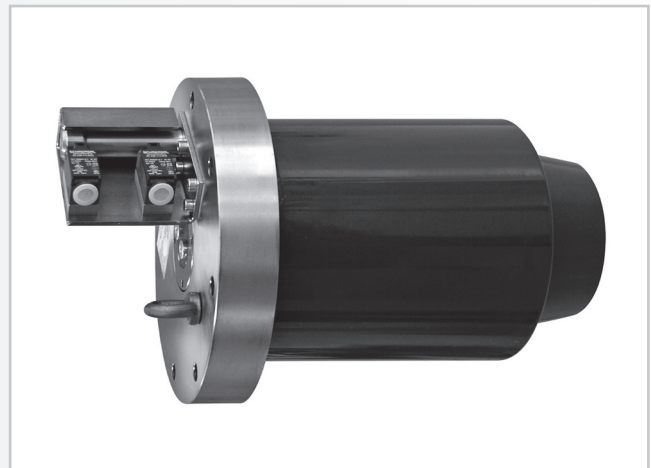
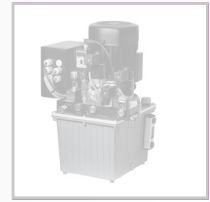
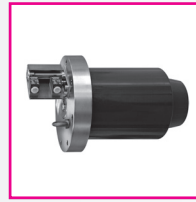

The **ROEMHELD rotor lock** works with hydraulic or electromechanical locking mechanism and withstands side loads up to 5,500 kN. The double-acting hydraulic cylinder generates the retracting and extending motion of the bolt and reliably locks the rotor blade of wind power plants up to 6.5 MW within a temperature range from  $-30^{\circ}\text{C}$  to  $+70^{\circ}\text{C}$ . A mechanical or inductive position monitoring of the bolt transmits the final positions "Rotor blade secured" and "Rotor free" to the system control and ensures additional safety.

- Very compact and maintenance-free version
- Modular design enables customer-specific customization
- FEM calculation and certification according to DEWI
- According to the guidelines of the Germanic Lloyd (GL)
- Corrosion protection in accordance with test standard DIN ISO 12944

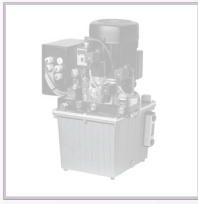

## Convenient access to the nacelle by electrical flap operation

For maintenance works at on and offshore wind power plants, the safe and simple opening of the entrance into the installations is important. Access and maintenance flaps must safely maintain their position and resist the harsh environmental conditions of wind and weather. ROEMHELD linear actuators work reliably and are designed for these requirements with their high-quality processing.



REpower Systems SE, Photo: Jan Oelker

The **ROEMHELD linear actuator RA 600** actuates flaps and hatches automatically at the push of a button. This electrical actuator is a complete function unit in a compact housing, and the sturdy design safely absorbs load peaks.

The RA 600 generates maximum forces up to 6,000 N, that can be used as push or pull forces. The long and maintenance-free service life is a convincing feature.

- Maintains the position also in case of power loss
- Corrosion-protected and vibration-resistant variants are available
- In addition suitable for regulation and control tasks
- Complies with the protection class IP 66 and IP 69 K

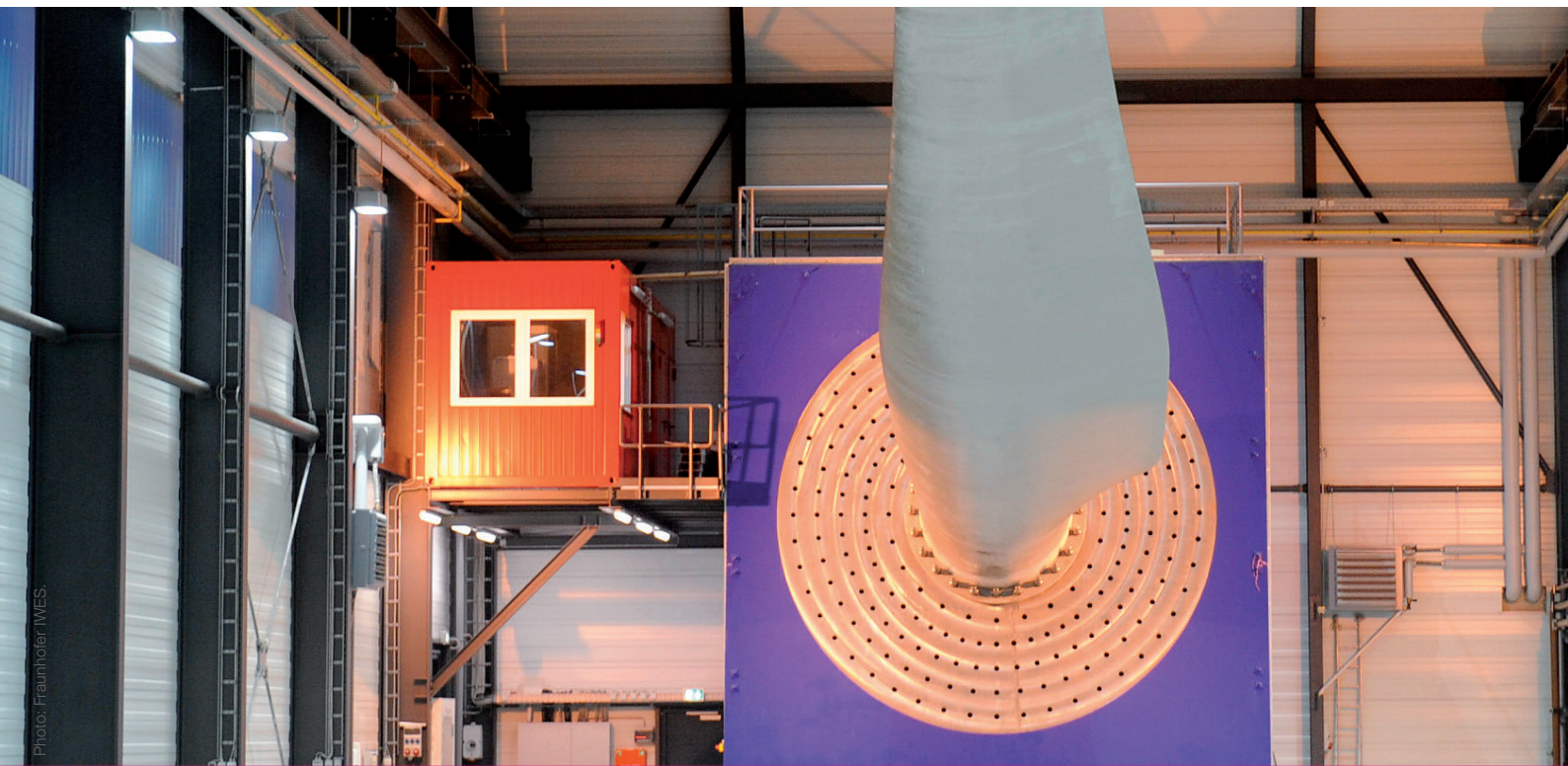
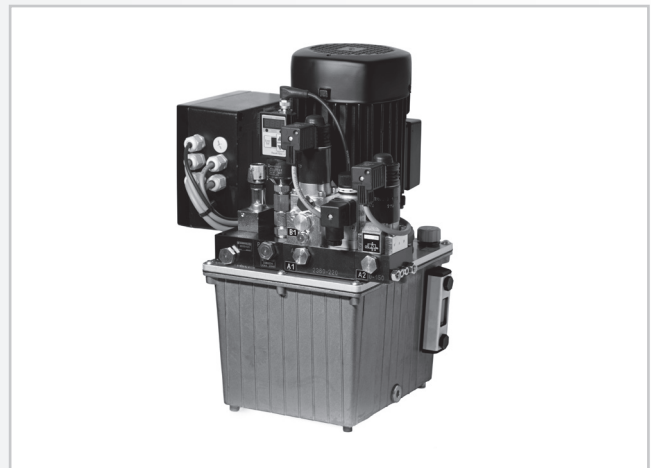
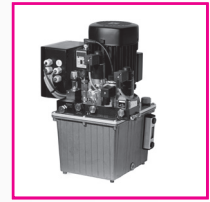
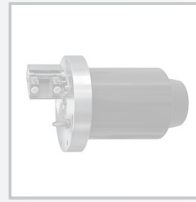

Photo: Fraunhofer IWES

## Workpieces of any form efficient and safe clamping

In industrial manufacturing, very different workpieces must be safely and precisely machined with high reproducibility. The cost and time-oriented production requires clamping in exact position and calculable set-up times.

With the world's largest selection of hydraulic clamping equipment, ROEMHELD is specialised to meet these requirements.



### Excerpt from the product portfolio



The **ROEMHELD hydraulic power unit** is also used in test benches for rotor brakes. They are used for endurance tests on "special test rigs" to test the durability of brake housings.



The **ROEMHELD zero-point mounting system Speedy Classic 3 NG** clamps and positions large and heavy workpieces with a repetitive accuracy of 10  $\mu$ . Adjustments and checks are completely omitted and thus the productivity is maximised.



With **ROEMHELD hollow-piston cylinders** large-sized workpieces can be hydraulically clamped with max. 160 kN per clamping point, whereby set-up times can be reduced up to 70 %.

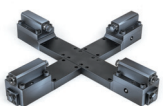

With **ROEMHELD concentric clamping elements** large and annular workpieces can be efficiently and concentrically aligned and clamped in a precise position. Alignment times are reduced to a minimum.



# Components for Wind Power Plants

## Rotor locks and more

Locking components and systems • Workpiece clamping elements • Workpiece clamping systems  
Machine vices • Zero-point mounting systems • Hydraulic cylinders • Hydraulic components  
Clamping and industrial power units • Tool clamping systems • Tool changing technology  
Magnetic clamping systems • Assembly and drive technology • System solutions



Römheld GmbH  
Friedrichshütte  
Römheldstraße 1–5  
35321 Laubach  
Germany

Tel.: +49 (0) 6405 89-0  
E-Mail: [info@roemheld.de](mailto:info@roemheld.de)  
[www.roemheld.com](http://www.roemheld.com)

Hilma-Römheld GmbH  
Auf der Landeskrone 2  
57234 Wilnsdorf-Wilden  
Germany

Tel.: +49 (0) 2739 4037-0  
E-Mail: [info@roemheld.de](mailto:info@roemheld.de)  
[www.roemheld.com](http://www.roemheld.com)

Stark Spannsysteme GmbH  
Römergrund 14  
6830 Rankweil  
Austria

Tel.: +43 (0) 5522 374 00-0  
E-Mail: [info@stark-roemheld.com](mailto:info@stark-roemheld.com)  
[www.stark-roemheld.com](http://www.stark-roemheld.com)