

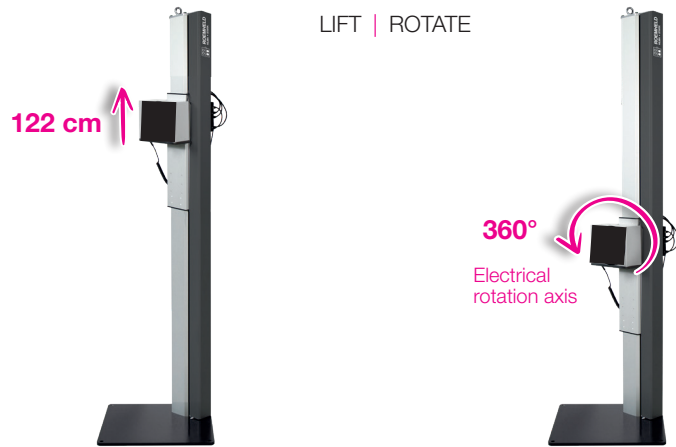

## moduLift

### Stationary Assembly Fixture, electrically operated



#### Application

The *moduLift* is a stationary, electrically operated assembly fixture for workpieces weighing up to 40 kg.

Up to 70 kg can be lifted without an electrical rotation axis.

#### Advantages

- Safe working environment thanks to self-retaining axes with 1225 mm electrical stroke and 360° electrical rotation axis
- Universal use with *moduhub* interfaces
- Compliant work due to design according to the EC Machinery Directive
- Collision shutdown
- Ergonomic working through best accessibility thanks to force-free rotation of the workpiece with electrical rotation axis
- Play-free guidance
- 15,000 cycles durability tested

#### Description

Due to its sturdy, industrial quality design *moduLift* can be used for both assembly and repair.

The lifting and rotation axis are electrically operated. Both axes are operated with a common hand panel.

Since both axes are self-locking, each set position is held securely.

A large stroke of 1225 mm makes it possible to lift the workpieces from the ground and bring them to an optimal assembly height. The rotation axis allows endless rotation at any height. The lifting axis has a shutdown function if a collision occurs during lowering.

#### Operation

Operation is via a hand panel that actuates the functions "Up/Down" and "Rotate left/Rotate right" ("Up/Down" only with 6415 834).

There is a holder on the slide for hanging the hand panel. The cable is approx. 2 m long when slackened.

#### Note

##### Mounting to the ground

The assembly fixture must be screwed to the floor, wall or ceiling in order to comply with the CE certification. For firm standing, the base plate must be bolted to the floor (min. concrete strength class C 20/25).

With larger base plates (available on request), the assembly fixture can also be used free-standing.

Alternatively, the *moduLift* can be fixed with the wall and ceiling mounting set. In harsh environmental conditions, however, it is always advisable to attach it to the floor.

#### Variants

Without rotation axis up to 70 kg load

#### Accessories on request

- Larger base plates
- Special clamping and mounting fixtures
- Further accessories under preparation

# Dimensions Technical data

## Dimensions

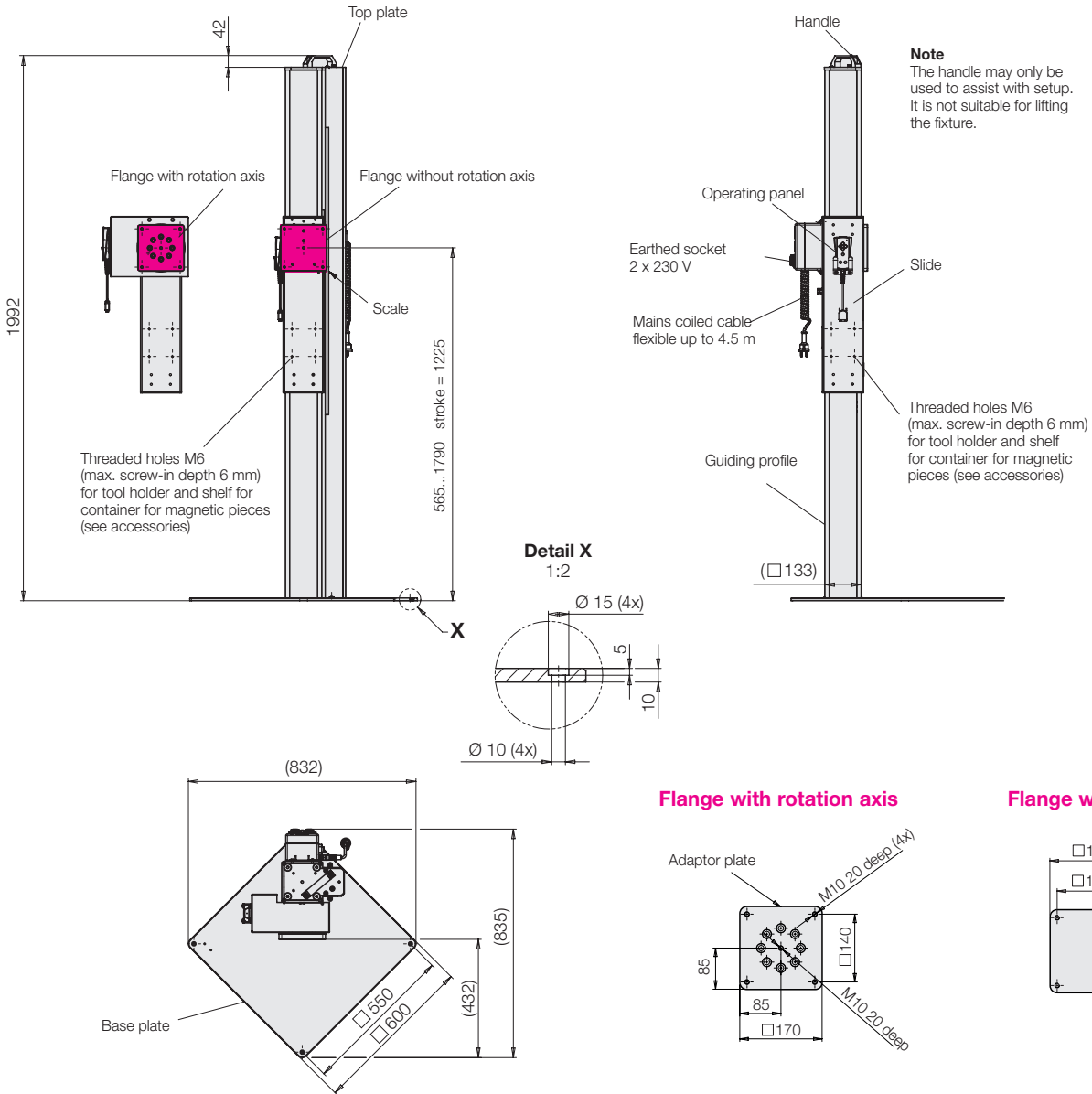

## Technical data

		With rotation axis	Without rotation axis
Max. workpiece weight	[kg]	40	70
Maximum permissible force application by operators	[N]	250	
Lifting drive		Electrically driven trapezoidal spindle	
Stroke	[mm]	1225	
Lifting speed (load-dependent)	[mm/s]	40 – 60	
Rotating drive		Electrically driven worm gear	
Rotation angle	[°]	360° – infinite	
Indexing angle	[°]	Self-retaining in any position	
Number of revolutions	[r.p.m.]	3	
Max. driving torque of rotation axis	[Nm]	90	
Max. bending moment	[Nm]	275	
Operating element		Hand panel	
Safety concept		Moving by touch control with self-locking drive elements and collision shutdown (lifting axis only)	
Supply voltage		230 V 1P / 50 Hz (16 A fused)	
Max. relative cycle time		33 sec. on / 5 min. break	
<b>Part no.</b>		<b>6415835</b>	<b>6415834</b>

**Note**  
 Exceeding the duty cycle or driving with an overload will damage the gearbox.