



Rosette di sicurezza

per dadi delle staffette di staffe rotanti

Soluzione per la produzione in proprio



Descrizione

Le rosette di sicurezza impediscono la torsione e/o l'allentamento dei dadi di fissaggio della staffetta. Importante: affinché la staffetta non possa ruotare sullo stelo pistone, il dado di fissaggio deve essere serrato con la coppia indicata nella tabella.

Ulteriori informazioni sul montaggio della staffetta sono disponibili nelle istruzioni di funzionamento della staffa rotante.

Le filettature nelle staffette per le viti di fissaggio devono essere realizzate dal cliente.

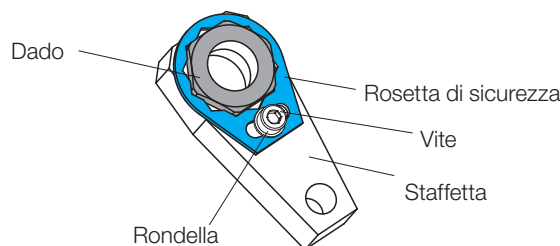

Staffa rotante 1853XXX

		No. ordin.
Dado	M12 x 1,5	3302115
Coppia di serraggio	12 Nm	
Vite a esagono incassato	M5 x 8	3301514
Coppia di serraggio	6 Nm	
Rondella	ISO 7089-5	3300079

Staffa rotante 1843XXX

		No. ordin.
Dado	M14 x 1,5	3527092
Coppia di serraggio	16 Nm	
Vite a esagono incassato	M5 x 8	3301514
Coppia di serraggio	6 Nm	
Rondella	ISO 7089-5	3300079

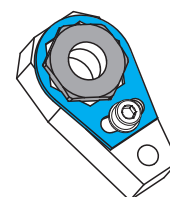
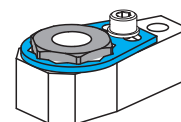
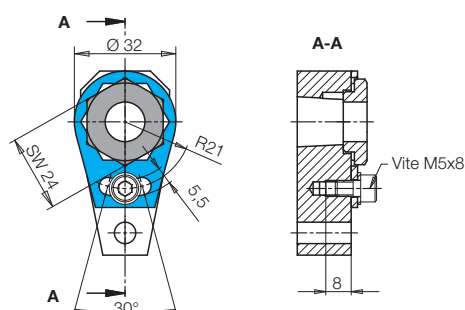
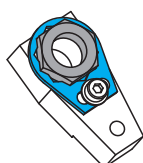
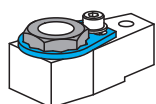
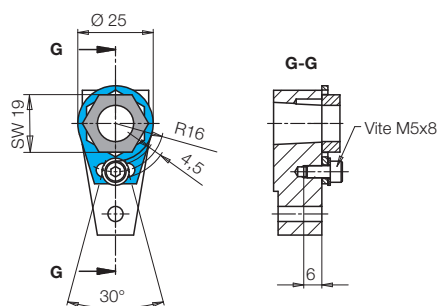

Staffa rotante 1893 XXX, 1844 XXX e 1854 XXX

		No. ordin.
Dado per 1893 e 1844	M18 x 1,5	3527014
Dado per 1854	M18 x 1,5	3301663
Coppia di serraggio	30 Nm	
Vite a esagono incassato	M5 x 8	3301514
Coppia di serraggio	6 Nm	
Rondella	ISO 7089-5	3300079

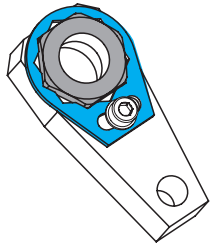
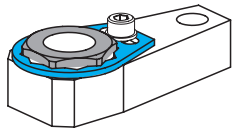
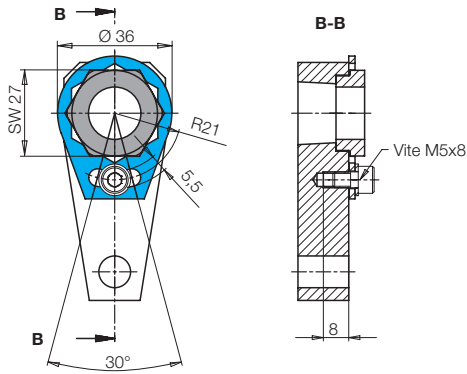

Staffa rotante 1845 XXX

		No. ordin.
Dado	M20 x 1,5	3527099
Coppia di serraggio	42 Nm	
Vite a esagono incassato	M5 x 8	3301514
Coppia di serraggio	6 Nm	
Rondella	ISO 7089-5	3300079

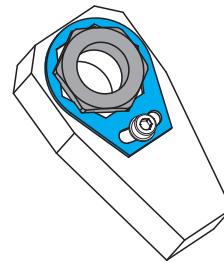
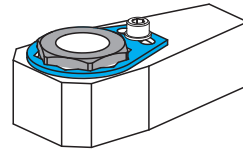
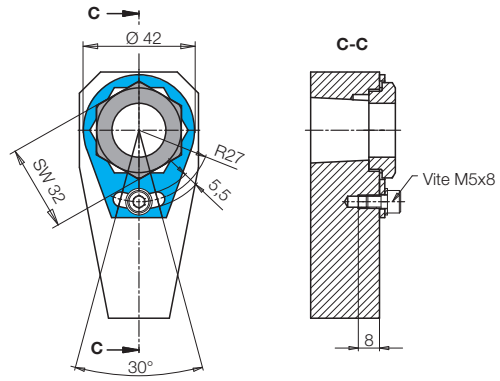

Staffa rotante 1895XXX, 1846XXX e 1856XXX

		No. ordin.
Dado per 1895 e 1846	M28 x 1,5	3527015
Coppia di serraggio	90 Nm	
Dado per 1856	M24 x 1,5	3302104
Coppia di serraggio	62 Nm	
Vite a esagono incassato	M6 x 10	3300223
Coppia di serraggio	10 Nm	
Rondella	ISO 7089-6	3300081

Staffa rotante 1896XXX

		Bestell-Nr.
Dado DIN 1804-W8	M35 x 1,5	3527048
Coppia di serraggio	160 Nm	
Vite a esagono incassato	M6 x 10	3300223
Coppia di serraggio	10 Nm	
Rondella	ISO 7089-6	3300081

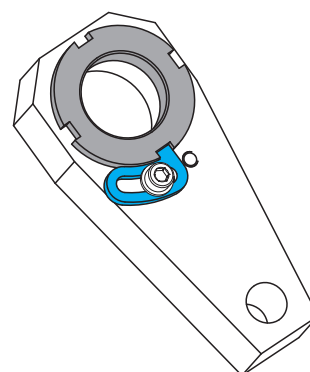
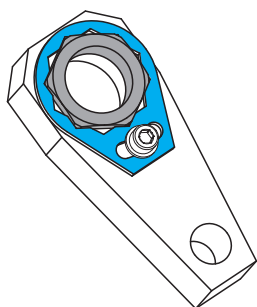
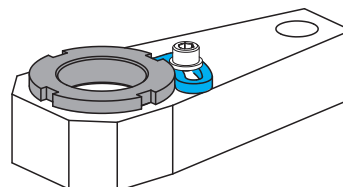
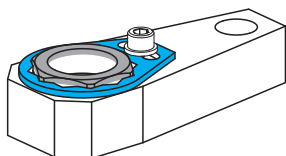
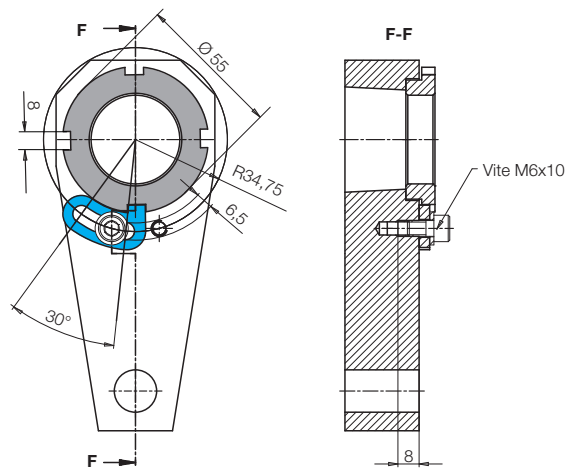
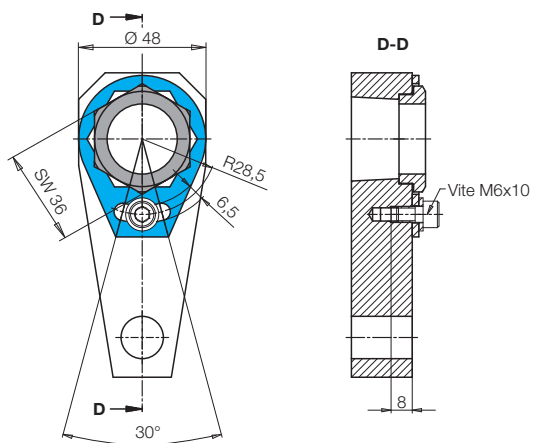

Staffa rotante 1897 XXX

		No. ordin.
Dado DIN 1804-W8	M45 x 1,5	3527016
Coppia di serraggio	280 Nm	
Vite a esagono incassato	M6 x 10	3300223
Coppia di serraggio	10 Nm	
Rondella	ISO 7089-6	3300081

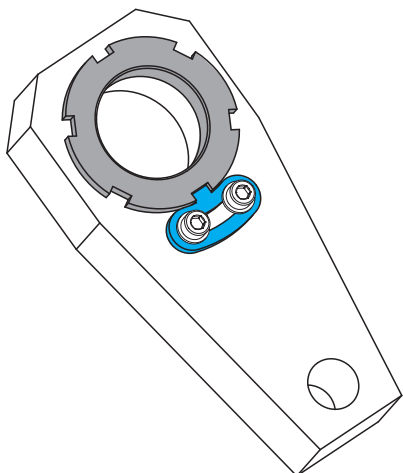
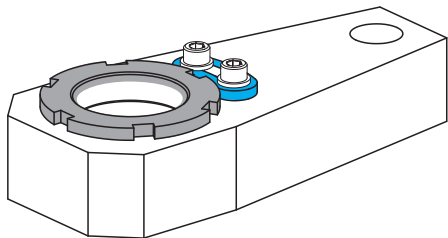
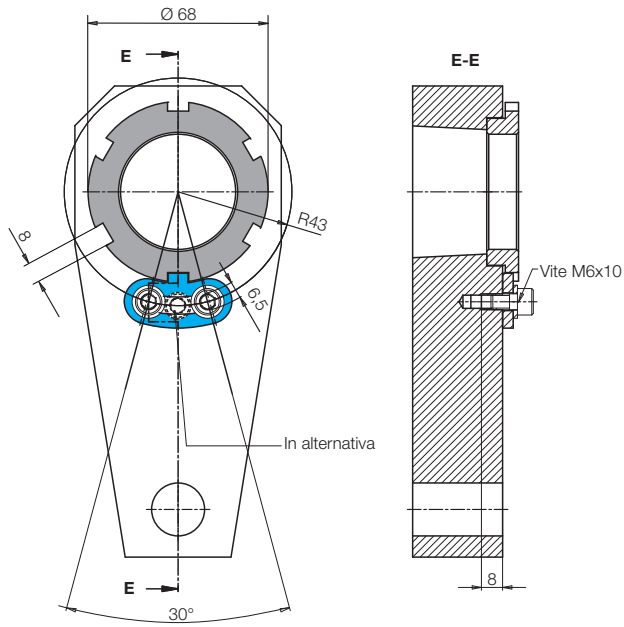

Staffa rotante 1857 XXX

		No. ordin.
Dado	M30 x 1,5	3302139
Coppia di serraggio	110 Nm	
Vite a esagono incassato	M6 x 10	3300223
Coppia di serraggio	10 Nm	
Rondella	ISO 7089-6	3300081

